



**Worktop induction hob/cooker-hood**  
**3-zones 88 cm**  
**Black**

EAN 5414425200184



## Cooker hood

### Dimensions hood (mm)

Dimensions (WxDxH) (mm) 818 x 165 x 760-840

### Energy label

Energy efficiency class (EEIhood)	B
Annual energy consumption (kWh/y) (AEChood)	50,5
Fluid Dynamic Efficiency class (FDEhood)	B
Lighting Efficiency class (LEhood)	-
Grease Filtering Efficiency class (GFEhood)	C

### General information

Integrated motor	•
Sound absorber	•
Number of metal grease filters	2
Recirculation (default setting)/ Duct out	• / •
Dimensions exhaust (mm)	89 x 222
Position exhaust	Bottom center / front / back

### Functions

Preadjusted extraction function (AUTO)	•
Manual extraction function	•
Control	Touch control
Touch control lock function	•
Number of speeds	5+ 3 intensive
Delayed switch off (minutes)	10-30
Grease filter cleaning indication	•
Recirculation filter cleaning indication	•
Removable glass	•
Aspiration heights (cm)	10, 20, 30 + freely adjustable
Watertank(s) for cleaning	2 upper, 2 lower

### Air flow & noise level

Air flow duct out (m <sup>3</sup> /u) (EN 61591):	
- Minimum	193
- Maximum	691
- Best efficiency point	346
Air pressure (Pa):	
- Maximum	437
- Best efficiency point	305
Sound pressure / power duct out setting (dB(A) re 1 pW)(EN 60704-2-13):	
- Minimum	27/37
- Maximum continues	46/57
- Maximum intensive	56/65
Sound pressure / power recirculation setting (dB(A) re 1 pW)(EN 60704-2-13):	
- Minimum	30/45
- Maximum continues	47/59
- Maximum intensive	55/67

# Induction hob

## General characteristics

---

Black opaque glass	•
Bevelled glass edge	•
Surface and flushline mounting	•

## Dimensions hob (mm)

---

Dimensions (WxDxH) (mm)	880 x 520 x 60
Cut-out worktop (WxD)(mm)	860 x 500
Dimensions cut-out with inset (WxDxH) (mm)	884 x 524 x 6

## Cooking zones

---

Octagonal zones (240 x 200 mm)	2
Power octagonal zones (W)	2100/3000 (Middle) 1600/1850 (Right)
Round zone (280 mm)	1
Power round zone (W)	2300/3000

## Cooking functions

---

Control	RED touch control
Power levels	9 + Power
Timer per zone	•
Minute minder	•
Stop&Go	-
Keep warm function	-
Automatic bridge function	• (1x)
Residual heat indication	•
Automatic cooking	-
Child lock function	•
Automatic pan recognition	-
Grill function	-

## Technical specifications

---

Maximum power	6.980 W
Voltage	230 V / 400 V + N
Power consumption in stand-by Ps (W)	<0,5 W
Weight (kg)	50,1

## Accessories

### Accessories

---

Grease filters	
- Grease filter left	1821020
- Grease filter right	1821134
Recirculation box	
- Recirculation box H 98 with Monoblock filter WHITE (98x818x290mm)	7921400
- Recirculation box H 98 with Monoblock filter BLACK (98x818x290mm)	7922400
- Recirculation box H 98 with Monoblock filter STAINLESS STEEL LOOK (98x818x290mm)	7923400

## Dimensions

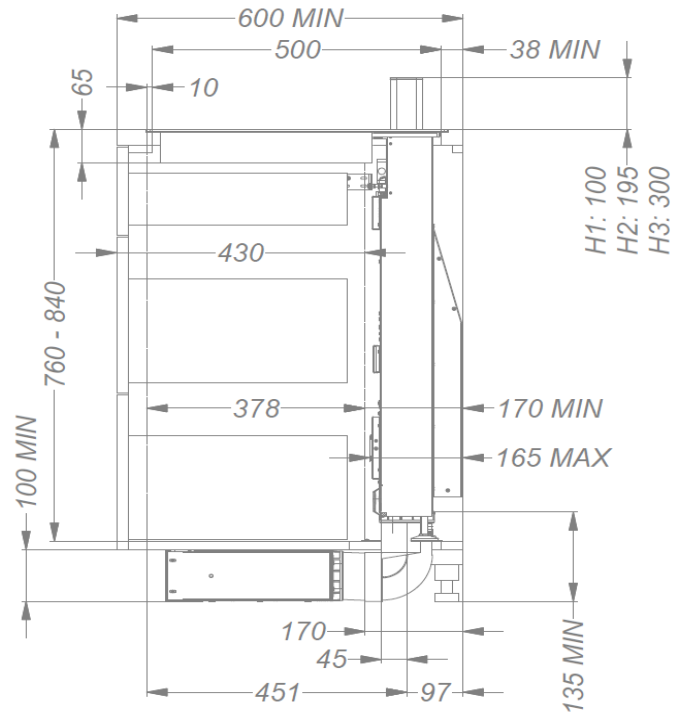
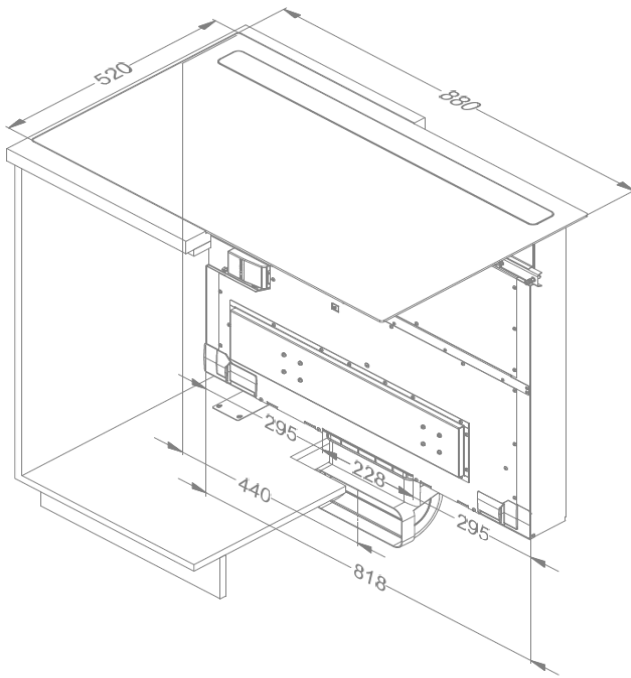

## Surface mounting

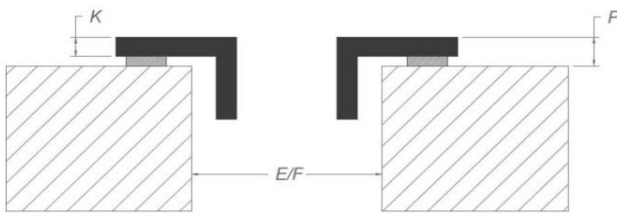

## Flushline mounting

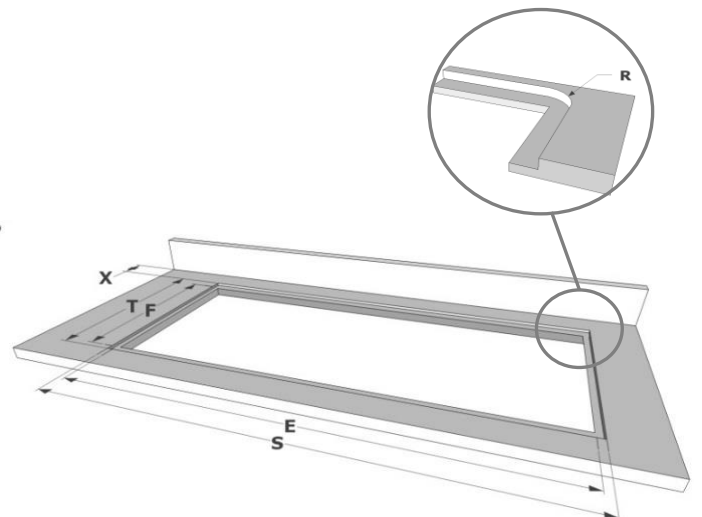
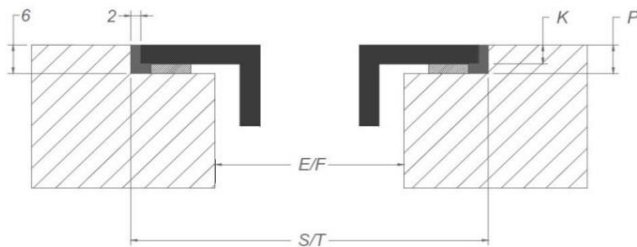

## Dimensions

	mm							
	E	F	K	P	R	S	T	X
Surface	860	500	4	6				38 min
Flushmount	860	500	4	6	8	884	524	38 min

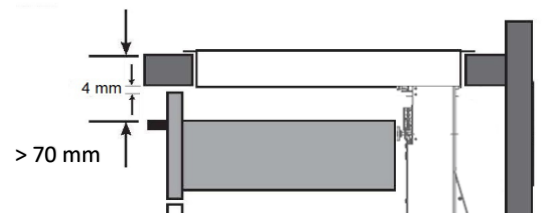

## Dimensions

